

NSR

COMMERCIAL REFRIGERATION



2024/2025



Qingdao NSR commercial refrigeration , invested and established in 2004 located in Qingdao, Shandong province, China.
 As one of the biggest commercial refrigeration manufacturer , our factory covers 13000 square meters with 800 workers and 5 production lines specialized in the production of Build-in and commercial equipment.
 To ensure the quality of our products, we established various lab rooms including 14 standard type labs and other life, noise, chemistry,electric labs to test every unit before shipment. After 20 years' development, become the biggest build-in refrigeration manufacturer exporting to 60 more countries around the world.
 From year 2021, we start commercial refrigeration field, we have succeeded to satisfy customer's request and develop many new series with high quality. Our products are widely accepted and highly approved by customers from over 30 countries and regions,mainly from Europe,America,Middle East and Southeast Asia.
 Warmly welcome friends from all over the world to visit and cooperate with us.



Product Advantages



EC fan motor
More efficiency and quiet



Top mount unit
Easy for cleaning and maintenance



New designed air duct
Better cooling efficiency

Hot pipe anti-condensation
Not just in the door frame,
but also in the middle vertical mullion,
instead of the Electric wire heater
More safe, more energy saving



Adjustable shelves
GN pans available

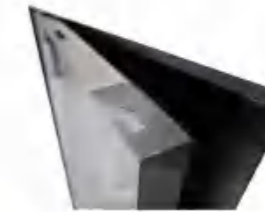

Full length, no welding, foam handle
More strong, more durable

UPRIGHT CABINET

VENTILATED GN656 SERIES



GN-656TN

Standard Features

- Freezer's door frame with Hot pipe anti-condensation
- Full length foam handle
- Shelves
- 4*Castors
- High pressure pipe with high corrosion-resistant coating
- LED light

Options

- Refrigerator's door frame with hot pipe anti-condensation
- 4*adjustable feet
- With middle small size shelves
- Welding full length handle
- C type recessed handle

Solid door

Glass door

Refrigerator

Freezer



GN-656TNG



GN-656BTM

Product Model	GN-656TN/TNG	GN-656BT/BTG	GN-656TNM	GN-656BTM
Unit dimensions (W/D/H mm)	740*830*2010	740*830*2010	740*830*2010	740*830*2010
Net capacity (L)	650	650	650	650
Cooling system	Ventilated	Ventilated	Ventilated	Ventilated
Temperature (°C)	-2~+8/+2~+8	-18~-22/-15~-20	-2~+8	-18~-22
Shelves No.	3	3	3	3
Interior light	LED light	LED light	LED light	LED light
Refrigerant	R290	R290	R290	R290
40 ' Container loading	40	40	40	40

UPRIGHT CABINET

VENTILATED GN1416 SERIES



GN-1416TN

Standard Features

- Freezer's door frame with Hot pipe anti-condensation
- Full length foam handle
- Shelves
- 4*Castors
- High pressure pipe with high corrosion-resistant coating
- LED light

Options

- Refrigerator's door frame with hot pipe anti-condensation
- 4*adjustable feet
- With middle small size shelves
- Welding full length handle
- C type recessed handle

Solid door

Glass door

Refrigerator

Freezer



GN-1416TNG



GN-1416BTM

Product Model	GN-1416TN/TNG	GN-1416BT/BTG	GN-1416TNM	GN-1416BTM
Unit dimensions (W/D/H mm)	1480*830*2010	1480*830*2010	1480*830*2010	1480*830*2010
Net capacity (L)	1300	1300	1300	1300
Cooling system	Ventilated	Ventilated	Ventilated	Ventilated
Temperature (°C)	-2~+8/+2~+8	-18~-22/-15~-20	-2~+8	-18~-22
Shelves No.	6	6	6	6
Interior light	LED light	LED light	LED light	LED light
Refrigerant	R290	R290	R290	R290
40 ' Container loading	15	15	15	15

UPRIGHT CABINET
VENTILATED GN600 SERIES



GN-600TN

Standard Features

- Freezer's door frame with Hot pipe anti-condensation
- Full length foam handle
- Shelves
- 4*Castors
- High pressure pipe with high corrosion-resistant coating
- LED light

Options

- Refrigerator's door frame with hot pipe anti-condensation
- 4*adjustable feet
- With middle small size shelves
- Welding full length handle
- C type recessed handle

Solid door

Glass door

Refrigerator

Freezer



GN-600TNG



GN-600BTM

Product Model	GN-600TN	GN-600TNG	GN-600BT	GN-600TNM	GN-600BTM
Unit dimensions (W/D/H mm)	680*810*2010	680*810*2010	680*810*2010	680*810*2010	680*810*2010
Net capacity (L)	600	600	600	600	600
Cooling system	Ventilated	Ventilated	Ventilated	Ventilated	Ventilated
Temperature (°C)	-2~+8	+2~+8	-18~-22	-2~+8	-18~-22
Shelves No.	3	3	3	3	3
Interior light	LED light	LED light	LED light	LED light	LED light
Refrigerant	R290	R290	R290	R290	R290
40 ' Container loading	42	42	42	42	42

UPRIGHT CABINET
VENTILATED GN1200 SERIES



GN-1200TN

Standard Features

- Freezer's door frame with Hot pipe anti-condensation
- Full length foam handle
- Shelves
- 4*Castors
- High pressure pipe with high corrosion-resistant coating
- LED light

Options

- Refrigerator's door frame with hot pipe anti-condensation
- 4*adjustable feet
- With middle small size shelves
- Welding full length handle
- C type recessed handle

Solid door

Glass door

Refrigerator

Freezer



GN-1200TNG

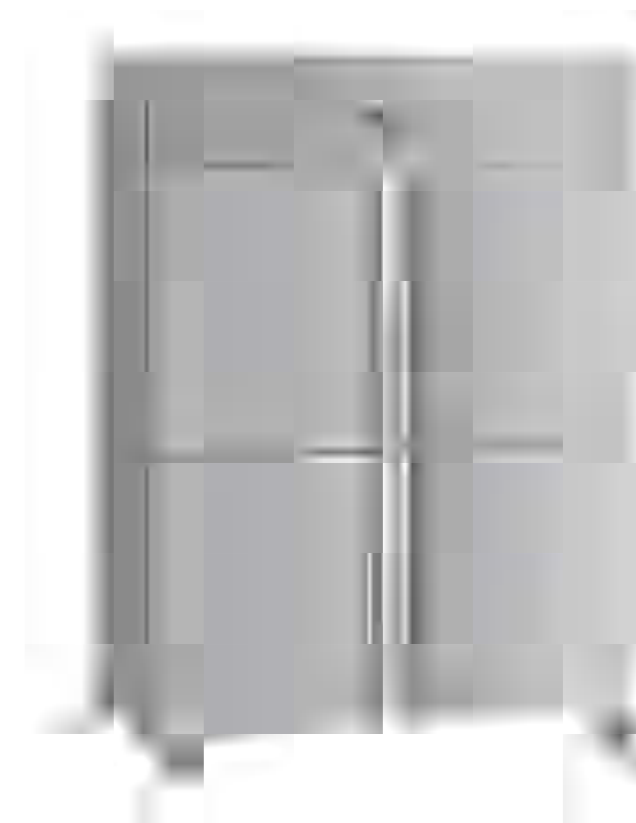

GN-1200BTM

Product Model	GN-1200TN	GN1200TNG	GN-1200BT	GN-1200TNM	GN-1200BTM
Unit dimensions (W/D/H mm)	1340*810*2010	1340*810*2010	1340*810*2010	1340*810*2010	1340*810*2010
Net capacity (L)	1200	1200	1200	1200	1200
Cooling system	Ventilated	Ventilated	Ventilated	Ventilated	Ventilated
Temperature (°C)	-2~+8	+2~+8	-18~-22	-2~+8	-18~-22
Shelves No.	6	6	6	6	6
Interior light	LED light	LED light	LED light	LED light	LED light
Refrigerant	R134a/R290	R134a/R290	R404a/R290	R134a/R290	R404a/R290
40' Container loading	22	22	22	22	22

Product Advantages



**Foam, no welding handle
more strong, more durable
with switch**



With door switch,energy saving

**Freezer with Hot pipe anti-condensation
in the door frame instead of the
Electric wire heater
More safe,more energy saving**



**Condenser unit slide out
Easy for cleaning and maintenance**



**High pressure coil with high
corrosion-resistant coating
more durable in water pan**

COUNTER
VENTILATED GN SERIES



GN-4100BT

Standard Features

- Freezer's door frame with Hot pipe anti-condensation
- Full length foam handle
- Shelves
- 4*Castors
- High pressure pipe with high corrosion-resistant coating

Options

- Refrigerator's door frame with hot pipe anti-condensation
- 4*adjustable feet
- With middle small size shelves
- Welding full length handle
- C type recessed handle

Solid door

Drawer

Refrigerator

Freezer



GN-2100TN



GN-3100TN

Product Model	GN-2100TN	GN-2100BT	GN-3100TN	GN-3100BT	GN-4100TN	GN-4100BT
Unit dimensions (W/D/H mm)	1360*700*860	1360*700*860	1795*700*860	1795*700*860	2230*700*860	2230*700*860
Net capacity (L)	282	282	417	417	553	553
Cooling system	Ventilated	Ventilated	Ventilated	Ventilated	Ventilated	Ventilated
Temperature (°C)	-2~+10	-18~-22	-2~+10	-18~-22	-2~+10	-18~-22
Shelves No.	2	2	3	3	4	4
Interior light	Option	Option	Option	Option	Option	Option
refrigerant	R290	R290	R290	R290	R290	R290
40 ' Container loading	48	48	38	38	32	32

COUNTER
WITH SPLASHBACK



GN-4200BT

Standard Features

- Freezer's door frame with Hot pipe anti-condensation
- Full length foam handle
- Shelves
- 4*Castors
- High pressure pipe with high corrosion-resistant coating



GN-2200TN

Options

- Refrigerator's door frame with hot pipe anti-condensation
- 4*adjustable feet
- With middle small size shelves
- Welding full length handle
- C type recessed handle

Product Model	GN-2200TN	GN-2200BT	GN-3200TN	GN-3200BT	GN-4200TN	GN-4200BT
Unit dimensions (W/D/H mm)	1360*700*950	1360*700*950	1795*700*950	1795*700*950	2230*700*950	2230*700*950
Net capacity (L)	282	282	417	417	553	553
Cooling system	Ventilated	Ventilated	Ventilated	Ventilated	Ventilated	Ventilated
Temperature (°C)	-2~+8	-18~-22	-2~+8	-18~-22	-2~+8	-18~-22
Shelves No.	2	2	3	3	4	4
Interior light	Option	Option	Option	Option	Option	Option
Refrigerant	R290	R290	R290	R290	R290	R290
40 ' Container loading	48	48	38	38	32	32

Solid door

Glass door

Refrigerator

Freezer

COUNTER
WITH GLASS GLASS DOOR



GN-2100TNG



GN-3100TNG



GN-4100TNG

Product Model	GN-2100TNG	GN-2100BTG	GN-3100TNG	GN-3100BTG	GN-4100TNG	GN-4100BTG
Unit dimensions (W/D/H mm)	1360*700*860	1360*700*860	1795*700*860	1795*700*860	2230*700*860	2230*700*860
Net capacity (L)	282	282	417	417	553	553
Cooling system	Ventilated	Ventilated	Ventilated	Ventilated	Ventilated	Ventilated
Temperature (°C)	+2~+8	-15~-20	+2~+8	-15~-20	+2~+8	-15~-20
Shelves No.	2	2	3	3	4	4
Interior light	Yes	Yes	Yes	Yes	Yes	Yes
Refrigerant	R290	R290	R290	R290	R290	R290
40 ' Container loading	48	48	38	38	32	32

COUNTER

VENTILATED TOP GLASS SERIES



GN-3100SALGC

Standard Features

- Full length foam handle
- Shelves
- 4*Castors
- High pressure pipe with high corrosion-resistant coating

Options

- Refrigerator's door frame with hot pipe anti-condensation
- 4*adjustable feet
- With middle small size shelves
- Welding full length handle
- C type recessed handle

Solid door

Glass lid

Refrigerator

Freezer

COUNTER

VENTILATED TOP GLASS SERIES



GN-3100SALSQ

Standard Features

- Full length foam handle
- Shelves
- 4*Castors
- High pressure pipe with high corrosion-resistant coating

Options

- Refrigerator's door frame with hot pipe anti-condensation
- 4*adjustable feet
- With middle small size shelves
- Welding full length handle
- C type recessed handle

Product Model	GN-2100SALGC	GN-3100SALGC	GN-4100SALGC
Unit dimensions (W/D/H mm)	1360*740*1365	1795*740*1365	2230*740*1365
Net capacity (L)	314	465	616
Cooling system	Ventilated	Ventilated	Ventilated
Temperature (°C)	+4~+10	+4~+10	+4~+10
Shelves No.	2	3	4
Interior light	Option	Option	Option
Refrigerant	R290	R290	R290
40 ' Container loading	48	38	32

Product Model	GN-2100SALSQ	GN-3100SALSQ	GN-4100SALSQ
Unit dimensions (W/D/H mm)	1360*740*1365	1795*740*1365	2230*740*1365
Net capacity (L)	314	465	616
Cooling system	Ventilated	Ventilated	Ventilated
Temperature (°C)	+4~+10	+4~+10	+4~+10
Shelves No.	2	3	4
Interior light	Option	Option	Option
Refrigerant	R290	R290	R290
40 ' Container loading	48	38	32

COUNTER
VENTILATED BAKERY COUNTER



PA-2100TN

Standard Features

- Full length foam handle
- Shelves
- 4*Castors
- High pressure pipe with high corrosion-resistant coating



PA-3100TN

Options

- Refrigerator's door frame with hot pipe anti-condensation
- 4*adjustable feet
- With middle small size shelves
- Welding full length handle
- C type recessed handle

Product Model	PA-2100TN	PA-3100TN
Unit dimensions (W/D/H mm)	1510*800*850	2020*800*850
Net capacity (L)	390	580
Cooling system	Ventilated	Ventilated
Temperature (°C)	+2~+8	+2~+8
Shelves No.	2	3
Interior light	Option	Option
Refrigerant	R290	R290
40 ' Container loading	30	28

Solid door

GN pan

SS lid

Refrigerator



SH-2000/700

Standard Features

- Full length foam handle
- Shelves
- 4*Castors
- High pressure pipe with high corrosion-resistant coating



SH-3000/800

Options

- Refrigerator's door frame with hot pipe anti-condensation
- 4*adjustable feet
- With middle small size shelves
- Welding full length handle
- C type recessed handle

Product Model	SH-2000/700	SH-2000/800	SH-3000/700	SH-3000/800
Unit dimensions (W/D/H mm)	1360*700*1085	1510*800*1085	1795*700*1085	2020*800*1085
Net capacity (L)	282	390	417	580
Cooling system	Ventilated	Ventilated	Ventilated	Ventilated
Temperature (°C)	+2~+8	+2~+8	+2~+8	+2~+8
Shelves No.	2	2	3	3
Interior light	Option	Option	Option	Option
Refrigerant	R290	R290	R290	R290
40 ' Container loading	48(HQ)	30(HQ)	38(HQ)	28(HQ)

COUNTER
VENTILATED PIZZA COUNTER



PZ-2600TN+VRX1500/380

Standard Features

- Freezer's door frame with Hot pipe anti-condensation
- Full length foam handle
- Shelves
- 4*Castors
- High pressure pipe with high corrosion-resistant coating



PZ-1610TN+VRX1500/380

Options

- Refrigerator's door frame with hot pipe anti-condensation
- 4*adjustable feet
- With middle small size shelves
- Welding full length handle
- C type recessed handle
- Black marble countertop

Product Model	PZ-2600TN	VRX-1500/380	PZ-1610TN	VRX-1500/380
Unit dimensions (W / D/ H mm)	1510*800*1000	1500*395*435	1510*800*1000	1500*395*435
Net capacity (L)	390	GN1/3*5+GN1/2*1	390	GN1/3*5+GN1/2*1
Cooling system	Ventilated	Static	Ventilated	Static
Temperature (°C)	+2~+8	0~+10	+2~+8	0~+10
Shelves No.	2	/	1	/
Interior light	Option	/	Option	/
Refrigerant	R290	R290	R290	R290
40 ' Container loading	30	261	30	261

Solid door

Pizza pan

Refrigerator

Granite



PZ-2610TN+VRX2000/380

Standard Features

- Freezer's door frame with Hot pipe anti-condensation
- Full length foam handle
- Shelves
- 4*Castors
- High pressure pipe with high corrosion-resistant coating



PZ-3600TN+VRX2000/380

Options

- Refrigerator's door frame with hot pipe anti-condensation
- 4*adjustable feet
- With middle small size shelves
- Welding full length handle
- C type recessed handle

Product Model	PZ-3600TN	VRX-2000/380	PZ-2610TN	VRX-2000/380
Unit dimensions (W / D/ H mm)	2020*800*1000	2000*395*435	2025*800*1000	2000*395*435
Net capacity (L)	580	GN1/3*9	580	GN1/3*9
Cooling system	Ventilated	Static	Ventilated	Static
Temperature (°C)	+2~+8	0~+10	+2~+8	0~+10
Shelves No.	3	/	2	/
Interior light	Option	/	Option	/
Refrigerant	R290	R290	R134a/R290	R290
40 ' Container loading	28	196	28	196

SALADETTE



S-900SQ

Standard Features

- Full length foam handle
- Shelves
- High pressure pipe with high corrosion-resistant coating

Options

- With middle small size shelves
- Welding full length handle
- C type recessed handle



S-903 6D



S-900

SALADETTE WITH SS LID



S-900

Standard Features

- Full length foam handle
- Shelves
- High pressure pipe with high corrosion-resistant coating



S-903

Options

- With middle small size shelves
- Welding full length handle
- C type recessed handle

Product Model	S-900	S-903
Unit dimensions (W / D/ H mm)	900*700*850	1365*700*850
Net capacity (L)	240	368
Cooling system	Static with fan cooling	Static with fan cooling
Temperature (°C)	0~+10	0~+10
Shelves No.	2	3
Refrigerant	R290	R290
40' Container loading	72	48

SALADETTE
WITH SS WORK TOP



S-901



S-901 2D



S-901 4D

Standard Features

- Full length foam handle
- Shelves
- High pressure pipe with high corrosion-resistant coating

Options

- With middle small size shelves
- Welding full length handle
- C type recessed handle

Product Model	S-901	S-901-2D	S-901-4D
Unit dimensions (W / D/ H mm)	900*700*850	900*700*850	900*700*850
Net capacity (L)	240	230	220
Cooling system	Static with fan cooling	Static with fan cooling	Static with fan cooling
Temperature (°C)	0~+10	0~+10	0~+10
Shelves No.	2	1 plus 2 Drawers GN1/2	4 Drawers GN1/2
Refrigerant	R290	R290	R290
40 ' Container loading	72	72	72

Solid door

Drawer

Refrigerator

SS lid



S-903S/S TOP

Standard Features

- Full length foam handle
- Shelves
- High pressure pipe with high corrosion-resistant coating



S-903 6D

Options

- With middle small size shelves
- Welding full length handle
- C type recessed handle

Product Model	S-903 S/S TOP	S-903-6D
Unit dimensions (W / D/ H mm)	1365*700*850	1365*700*850
Net capacity (L)	368	368
Cooling system	Static with fan cooling	Static with fan cooling
Temperature (°C)	0~+10	0~+10
Shelves No.	3	6 Drawers GN1/2
Refrigerant	R290	R290
40 ' Container loading	48	48

SALADETTE
WITH SS LID AND WORK TOP



PS-200

Standard Features

- Full length foam handle
- Shelves
- High pressure pipe with high corrosion-resistant coating



PS-300

Options

- With middle small size shelves
- Welding full length handle
- C type recessed handle

Product Model	PS-200	PS-300
Unit dimensions (W / D/ H mm)	900*700*970	1365*700*970
Net capacity (L)	240	392
Cooling system	Static with fan cooling	Static with fan cooling
Temperature (°C)	0~+10	0~+10
Shelves No.	2	3
Refrigerant	R290	R290
40 ' Container loading	72	48

Solid door

Drawer

Refrigerator

SS lid

SALADETTE
WITH GN COVER GRANITE WORK TOP



PS-900

Standard Features

- Full length foam handle
- Shelves
- High pressure pipe with high corrosion-resistant coating



PS-903

Options

- With middle small size shelves
- Welding full length handle
- C type recessed handle

Product Model	PS-900	PS-903
Unit dimensions (W/D/H mm)	900*700*1075	1365*700*1075
Net capacity (L)	240	402
Cooling system	Static with fan cooling	Static with fan cooling
Temperature (°C)	0~+10	0~+10
Shelves No.	2	3
Refrigerant	R290	R290
40 ' Container loading	72	48(HQ)

SALEDETTE
WITH PIZZA PREP TOP AND VRX



S-903 PZ+VRX1400/330

Standard Features

- Full length foam handle
- Shelves
- High pressure pipe with high corrosion-resistant coating

Options

- With middle small size shelves
- Welding full length handle
- C type recessed handle

Product Model	S-903PZ	VRX-1400/330
Unit dimensions (W/D/H mm)	1400*700*1020	1400*335*435
Net capacity (L)	368	GN1/4*6
Cooling system	Static with fan cooling	Static
Temperature (°C)	0~+10	0~+10
Shelves No.	3	2
Refrigerant	R290	R290
40 ' Container loading	48(HQ)	343

Solid door

GN pan

Refrigerator

Granite

SALEDETTE
WITH GLASS COVER



S-900CG

Standard Features

- Full length foam handle
- Shelves
- High pressure pipe with high corrosion-resistant coating



S-903SQ

Options

- With middle small size shelves
- Welding full length handle
- C type recessed handle

Product Model	S-900SQ	S-903SQ	S-900CG	S-903CG
Unit dimensions (W/D/H mm)	900*700*850	1365*700*850	900*700*850	1365*700*850
Net capacity (L)	240	368	240	368
Cooling system	Static with fan cooling	Static with fan cooling	Static with fan cooling	Static with fan cooling
Temperature (°C)	0~+10	0~+10	0~+10	0~+10
Shelves No.	2	3	2	3
Refrigerant	R290	R290	R290	R290
40 ' Container loading	72	48	72	48

REACH-IN
CONDENSER UNIT BOTTOM MOUNTED



NRB27R

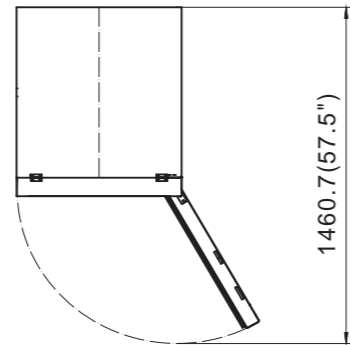
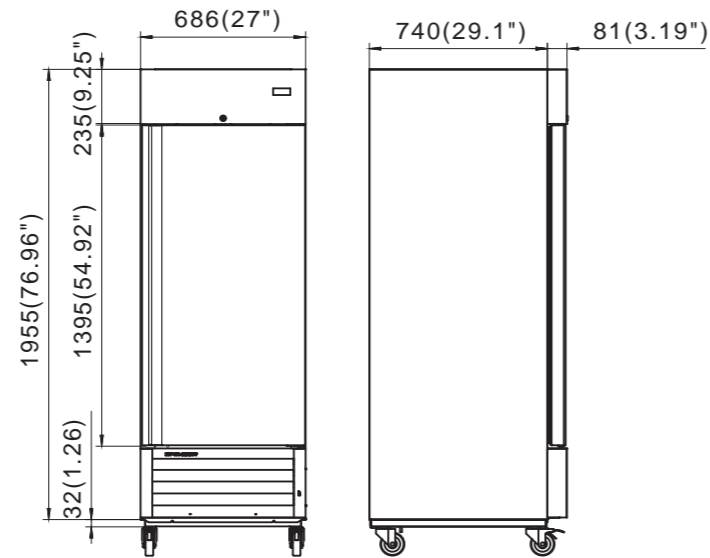

NRB27R&NRB27F

Standard Features

- American fashionable style upright cabinet chiller/freezer
- Exterior material SS430, interior Pre-coated Aluminum
- Reversible doors and automatically self close when less than 90°open
- Inner box curved edges for easy cleaning
- Magnetic sealing strip keeps the cold air inside. Easy to remove without use of tools
- With Lock and key
- Digital thermostat Italian famous brand Dixell,Carel



NRB54R

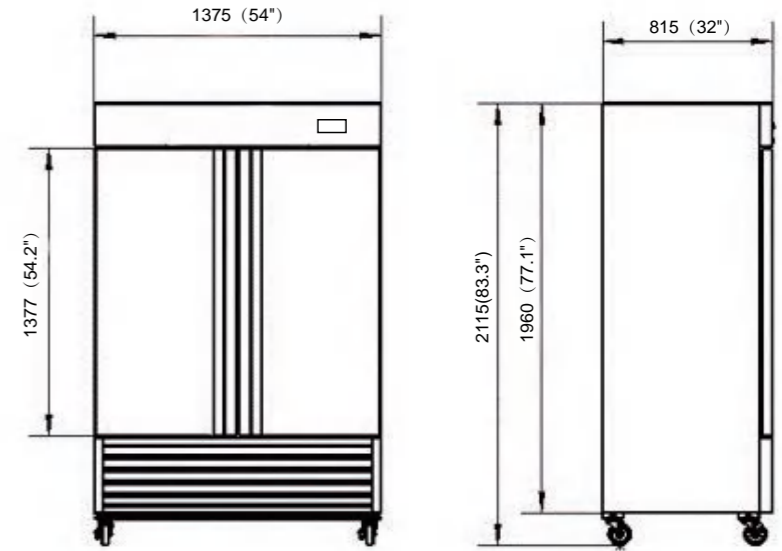

NRB54R&NRB54F

Product Model	NRB27R	NRB27F	NRB54R	NRB54F
Unit dimensions (W/D/H mm)	686*815*2115	686*815*2115	1375*815*2115	1375*815*2115
Unit dimensions (W / D/ H inch)	27 *32 1/16*83 1/4	27 *32 1/16*83 1/4	54 1/8*32 1/16*83 1/4	54 1/8*32 1/16*83 1/4
Packing imensions (W/D/H mm)	766*875*2265	766*875*2265	1435*875*2265	1435*875*2265
Packing dimensions (W / D/ H inch)	30 3/16*35 3/16*85 1/16	30 3/16*35 3/16*85 1/16	56 5/16*35 3/16*85 1/16	56 5/16*35 3/16*85 1/16
Net Capacity(L)	594	594	1302	1302
Cooling System	Ventilated	Ventilated	Ventilated	Ventilated
Temperature range(°F)	28~46	0~-8	28~46	0~-8
Kind Of Refrigerant	R290	R290	R290	R290
Light	LED	LED	LED	LED
Number of Shelves	3	3	6	6
Number of Door	1	1	2	2
40 ' Container load	39	39	21	21

REACH-IN
CONDENSER UNIT TOP MOUNTED



NRT27R

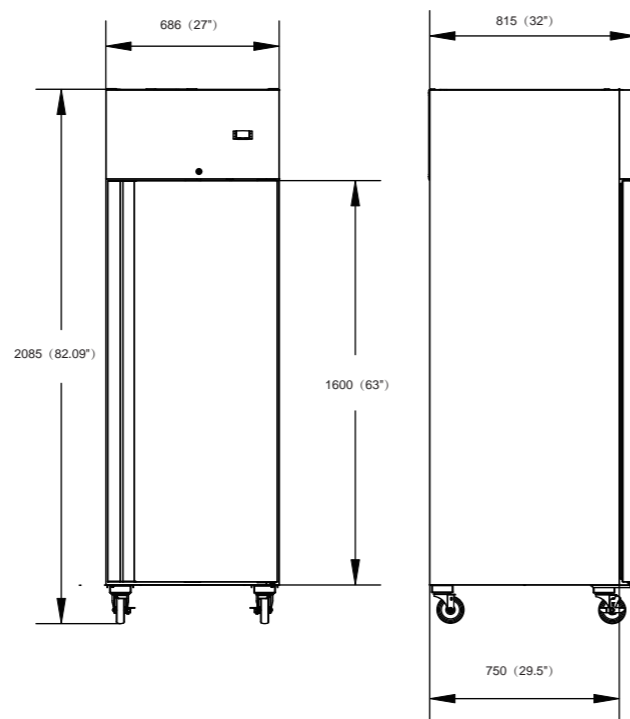

NRT27R&NRT27F

Standard Features

- American fashionable style upright cabinet chiller/freezer
- Exterior material SS430, interior Pre-coated Aluminum
- Reversible doors and automatically self close when less than 90°open
- Inner box curved edges for easy cleaning
- Magnetic sealing strip keeps the cold air inside. Easy to remove without use of tools
- With Lock and key
- Digital thermostat Italian famous brand Dixell,Carel



NRT54R

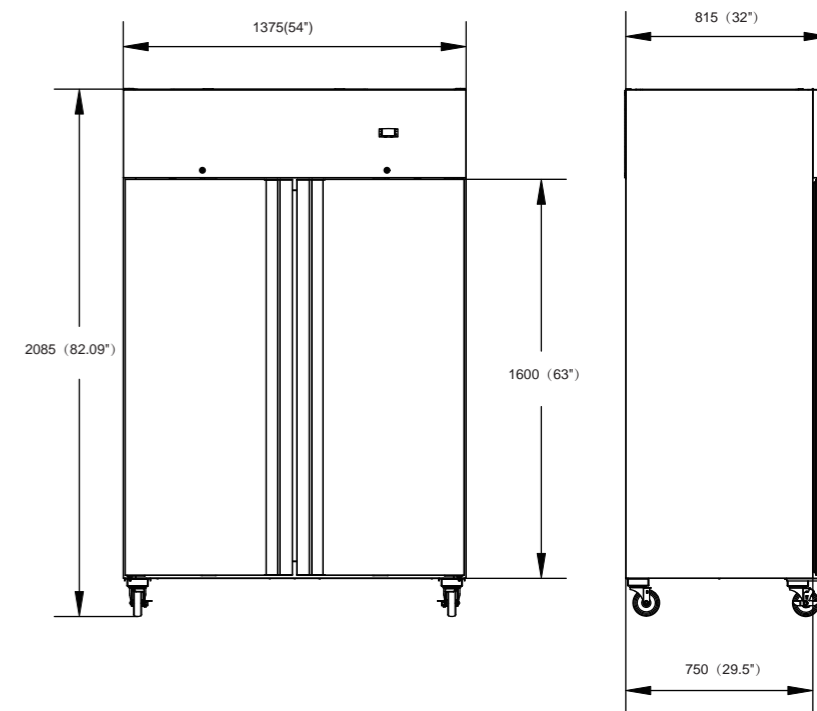

NRT54R&NRT54F

Product Model	NRT27R	NRT27F	NRT54R	NRT54F
Unit dimensions (W/D/H mm)	686*815*2085	686*815*2085	1375*815*2085	1375*815*2085
Unit dimensions (W / D/ H inch)	27 *32 1/16*82 1/16	27 *32 1/16*82 1/16	54 1/8*32 1/16*82 1/16	54 1/8*32 1/16*82 1/16
Packing imensions (W/D/H mm)	766*875*2265	766*875*2265	1435*875*2265	1435*875*2265
Packing dimensions (W / D/ H inch)	30 3/16*35 3/16*85 1/16	30 3/16*35 3/16*85 1/16	56 5/16*35 3/16*85 1/16	56 5/16*35 3/16*85 1/16
Net Capacity(L)	594	594	1302	1302
Cooling System	Ventilated	Ventilated	Ventilated	Ventilated
Temperature range(°F)	28~46	0~-8	28~46	0~-8
Kind Of Refrigerant	R290	R290	R290	R290
Light	LED	LED	LED	LED
Number of Shelves	3	3	6	6
Number of Door	1	1	2	2
40 ' Container load	39	39	21	21

UNDER COUNTER



NUC-29R



NUC-60R

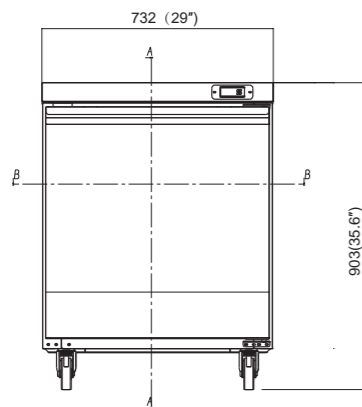
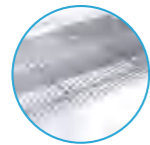

NUC-29R

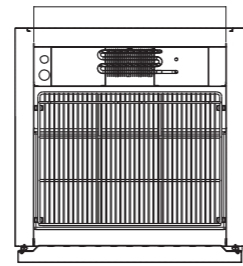
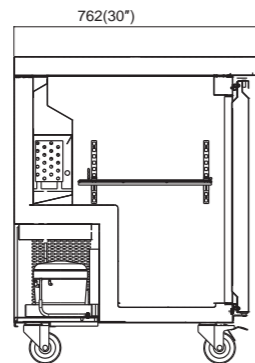

Standard Features

- American fashionable style counter
- Exterior material SS430, interior Pre-coated Aluminum
- Reversible doors and automatically self close when less than 90° open
- Inner box curved edges for easy cleaning
- Magnetic sealing strip keeps the cold air inside. Easy to remove without use of tools
- With Lock and key
- Digital thermostat Italian famous brand Dixell, Carel

Options

- Adjustable stainless steel feet or lockable castors
- Special various front panel design according to customer request

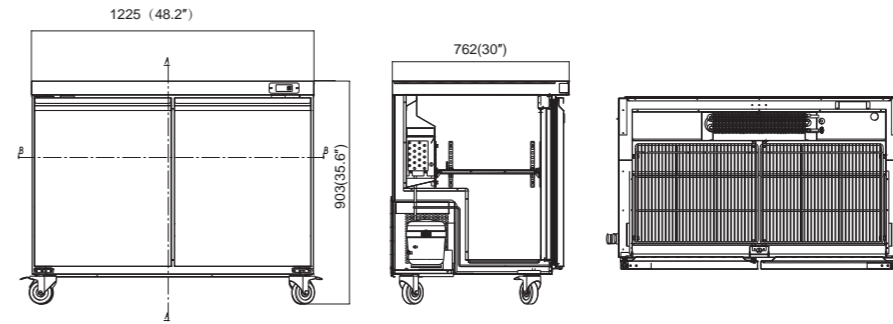

NUC-48R

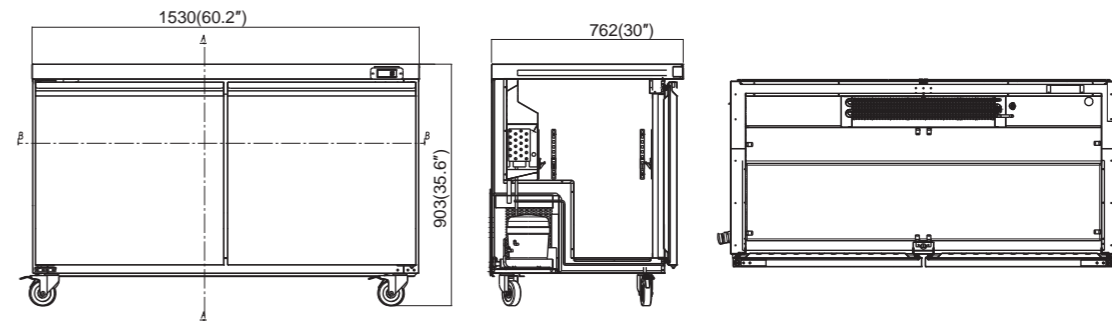

NUC-60R

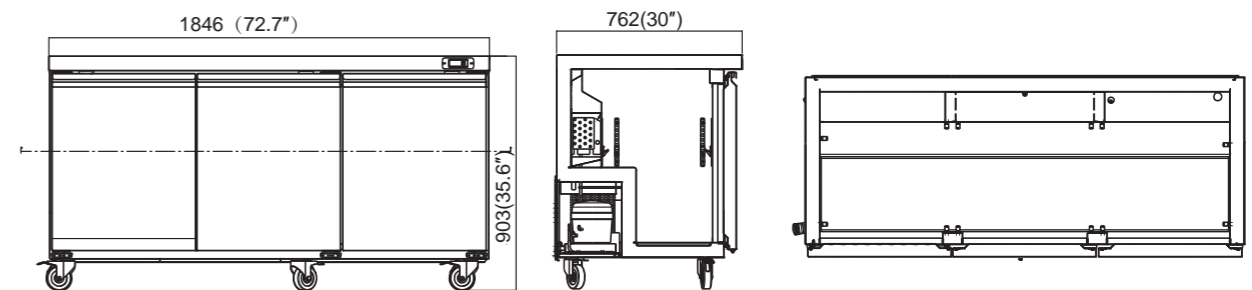

NUC-72R

Product Model	NUC29R	NUC48R	NUC60R	NUC72R
Unit dimensions (W / D/ H mm)	732*762*903	1225*762*903	1530*762*903	1846*762*903
Unit dimensions (W / D/ H inch)	29*30*35 9/16	48 1/4*30*35 9/16	60 1/4*30*35 9/16	72 11/16*30*35 9/16
Packing dimensions (W / D/ H mm)	782*852*962	1275*852*962	1580*852*962	1899*852*962
Packing dimensions (W / D/ H inch)	30 3/4*33 9/16*37 7/8	50 3/16*33 9/16*37 7/8	62 3/16*33 9/16*37 7/8	74 3/4*33 9/16*37 7/8
Net capacity (CUFT)	6.7	11.1	14.1	16.6
Net Capacity(L)	190	314	399	470
Cooling System	Ventilated	Ventilated	Ventilated	Ventilated
Temperature range(°F)	35~46	35~46	35~46	35~46
Kind Of Refrigerant	R290	R290	R290	R290
Number of Shelves	1	2	2	3
Number of Door	1	2	2	3
40 ' Container load	60	44	28	26

UNDER COUNTER



NUC-29F



NUC-60F

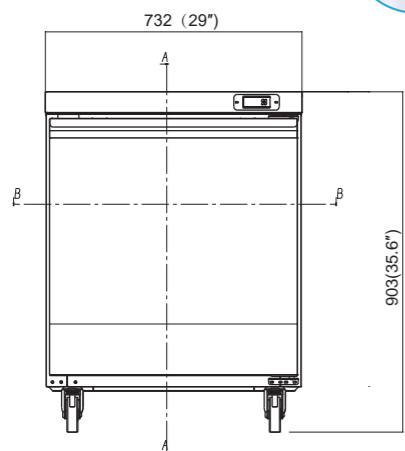

NUC-29F

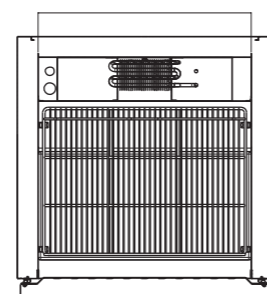
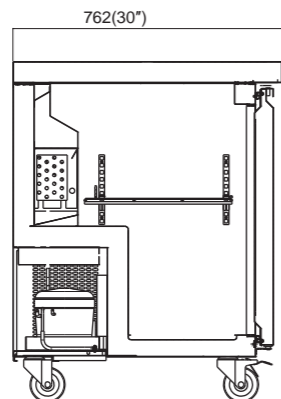

Standard Features

- American fashionable style counter
- Exterior material SS430, interior Pre-coated Aluminum
- Reversible doors and automatically self close when less than 90° open
- Inner box curved edges for easy cleaning
- Magnetic sealing strip keeps the cold air inside. Easy to remove without use of tools
- With Lock and key
- Digital thermostat Italian famous brand Dixell, Carel

Options

- Adjustable stainless steel feet or lockable castors
- Special various front panel design according to customer request

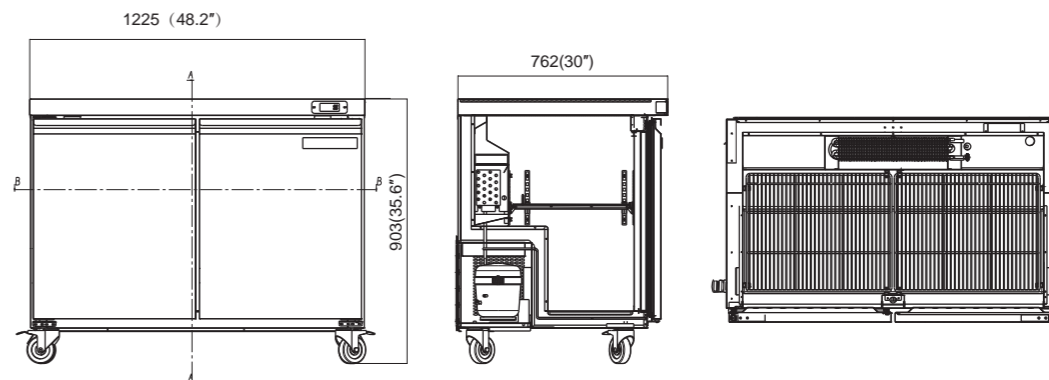

NUC-48F

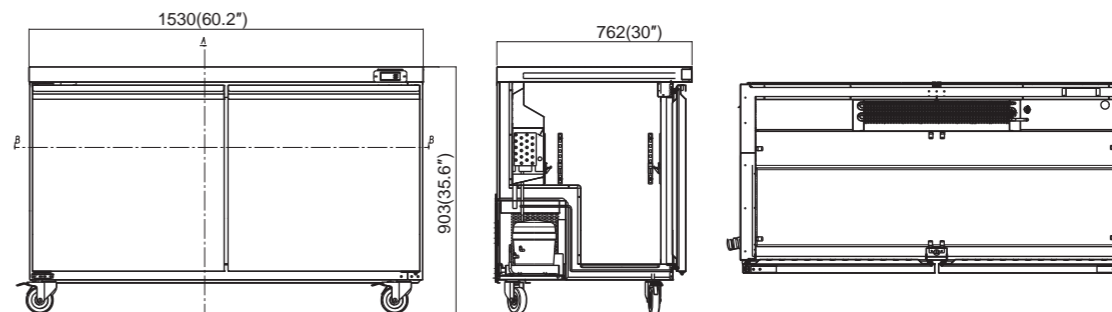

NUC-60F

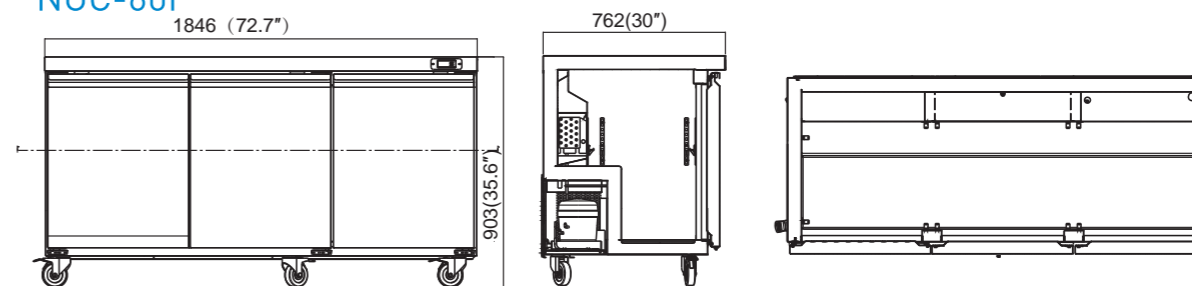

NUC-72F

Product Model	NUC29F	NUC48F	NUC60F	NUC72F
Unit dimensions (W / D/ H mm)	732*762*903	1225*762*903	1530*762*903	1846*762*903
Unit dimensions (W / D/ H inch)	29*30*35 9/16	48 1/4*30*35 9/16	60 1/4*30*35 9/16	72 11/16*30*35 9/16
Packing dimensions (W / D/ H mm)	782*852*962	1275*852*962	1580*852*962	1899*852*962
Packing dimensions (W / D/ H inch)	30 3/4*33 9/16*37 7/8	50 3/16*33 9/16*37 7/8	62 3/16*33 9/16*37 7/8	74 3/4*33 9/16*37 7/8
Net capacity (CUFT)	6.7	11.1	14.1	16.6
Net Capacity(L)	190	314	399	470
Cooling System	Ventilated	Ventilated	Ventilated	Ventilated
Temperature range(°F)	0~-8	0~-8	0~-8	0~-8
Kind Of Refrigerant	R290	R290	R290	R290
Number of Shelves	1	2	2	3
Number of Door	1	2	2	3
40 ' Container load	60	44	28	26

PIZZA PREP TABLE



NPP-93



Standard Features

- American fashionable style Saladette
- Exterior material SS430, interior Pre-coated Aluminum
- Reversible doors and automatically self close when less than 90°open
- Inner box curved edges for easy cleaning
- Magnetic sealing strip keeps the cold air inside. Easy to remove without use of tools
- With Lock and key
- Digital thermostat Italian famous brand Dixell,Carel

Options

- Adjustable stainless steel feet or lockable castors

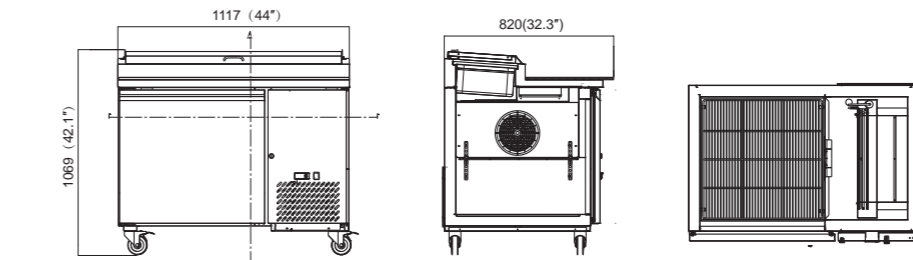

NPP-44

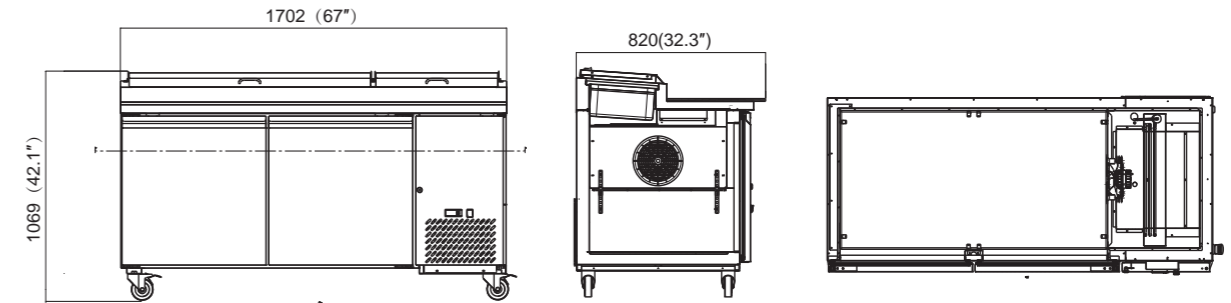

NPP-67

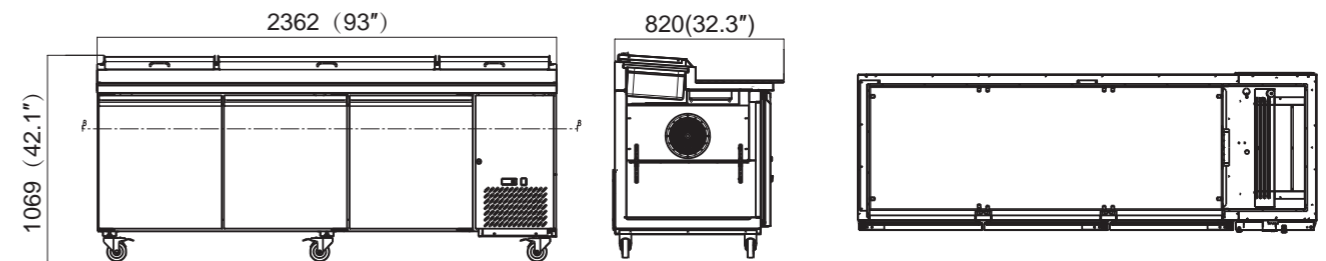

NPP-93

Product Model	NPP-44	NPP-67	NPP-93
Unit dimensions (W / D/ H mm)	1117*820*1069	1702*820*1069	2362*820*1069
Unit dimensions (W / D/ H inch)	44*32 5/16*42 1/16	67 *32 5/16*42 1/16	93*32 5/16*42 1/16
Packing dimensions (W / D/ H mm)	1142*880*1136	1727*880*1136	2387*880*1136
Packing dimensions (W / D/ H inch)	45*34 5/8*44 3/4	68*34 5/8*44 3/4	94*34 5/8*44 3/4
Net capacity (CUFT)	10.9	20.9	30.8
Net Capacity(L)	310L	592L	872L
Cooling System	Ventilated	Ventilated	Ventilated
Temperature range(°F)	32~50	32~50	32~50
Kind Of Refrigerant	R290	R290	R290
Number of Shelves	1	2	3
Number of Door	1	2	3
40 ' Container loading	42	24	16

SALAD AND SANDWICH PREP TABLE



NSP-48



NSP-72

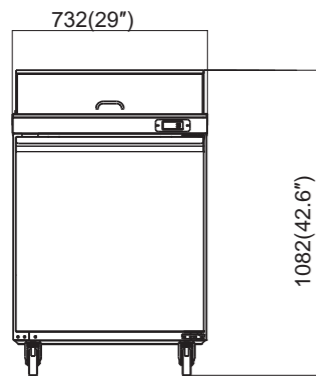
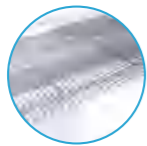

NSP-29

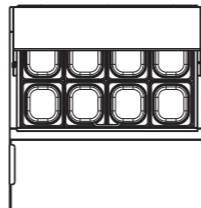
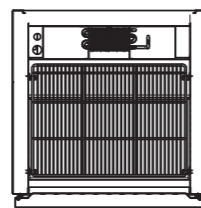
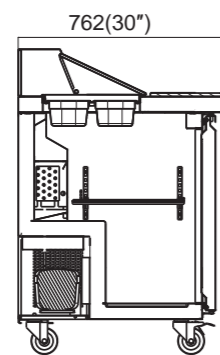

Options

- Adjustable stainless steel feet or lockable castors

Standard Features

- American fashionable style Saladette
- Exterior material SS430, interior Pre-coated Aluminum
- Reversible doors and automatically self close when less than 90°open
- Inner box curved edges for easy cleaning
- Magnetic sealing strip keeps the cold air inside. Easy to remove without use of tools
- With Lock and key
- Digital thermostat Italian famous brand Dixell,Carel

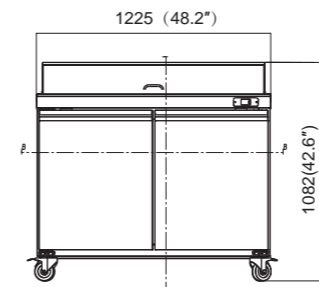

NSP-48

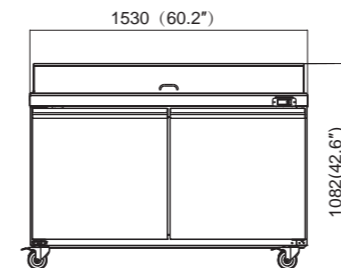
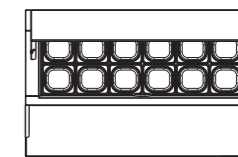
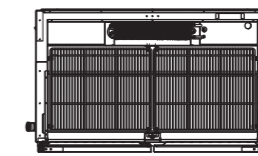
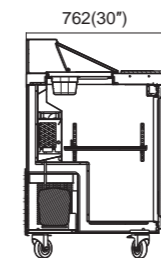

NSP-60

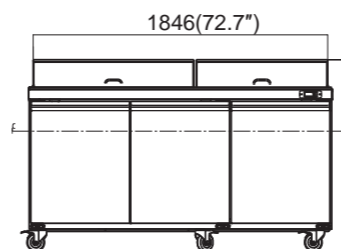
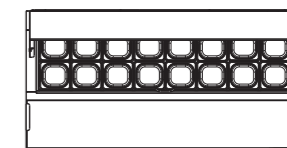
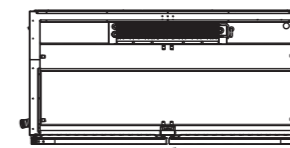
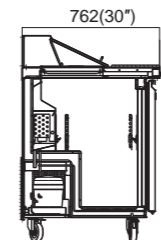

NSP-72

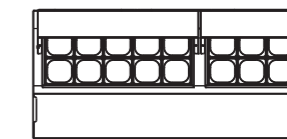
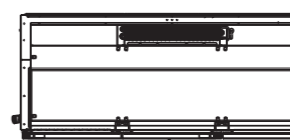
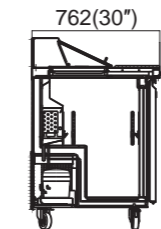

Product Model	NSP-29	NSP-48	NSP-60	NSP-72
Unit dimensions (W / D/ H mm)	732*762*1082	1225*762*1082	1530*762*1082	1846*762*1082
Unit dimensions (W / D/ H inch)	29*30*42 5/8	48 1/4*30*42 5/8	60 1/4*30*42 5/8	72 11/16*30*42 5/8
Packing dimensions (W / D/ H mm)	782*728*1165	1275*728*1165	1580*728*1165	1899*728*1165
Packing dimensions (W / D/ H inch)	30 3/4*28 11/16*45 7/8	50 3/16*28 11/16*45 7/8	62 3/16*28 11/16*45 7/8	74 12/16*28 11/16*45 7/8
Net capacity (CUFT)	7.6	13.8	17.8	21.2
Net Capacity(L)	215L	390L	505L	601L
Cooling System	Ventilated	Ventilated	Ventilated	Ventilated
Temperature range(°F)	32~50	32~50	32~50	32~50
Kind Of Refrigerant	R290	R290	R290	R290
Number of Shelves	1	2	2	3
Number of Door	1	2	2	3
40 ' Container load	60	44	28	26

SALAD AND SANDWICH PREP TABLE



NSP-29(M)



NSP-48(M)

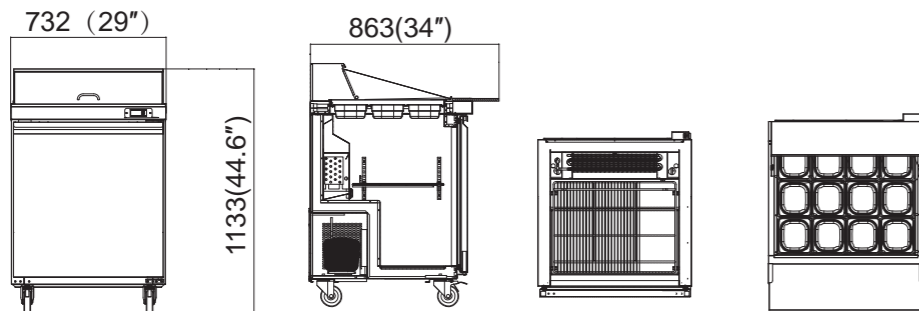

NSP-29(M)

Options

- Adjustable stainless steel feet or lockable castors

Standard Features

- American fashionable style Saladette
- Exterior material SS430, interior Pre-coated Aluminum
- Reversible doors and automatically self close when less than 90°open
- Inner box curved edges for easy cleaning
- Magnetic sealing strip keeps the cold air inside. Easy to remove without use of tools
- With Lock and key
- Digital thermostat Italian famous brand Dixell,Carel

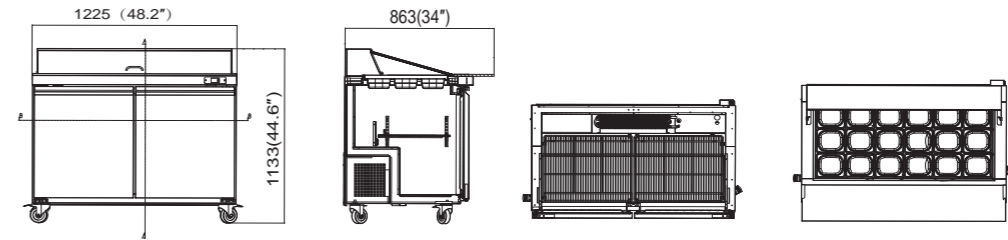

NSP-48(M)

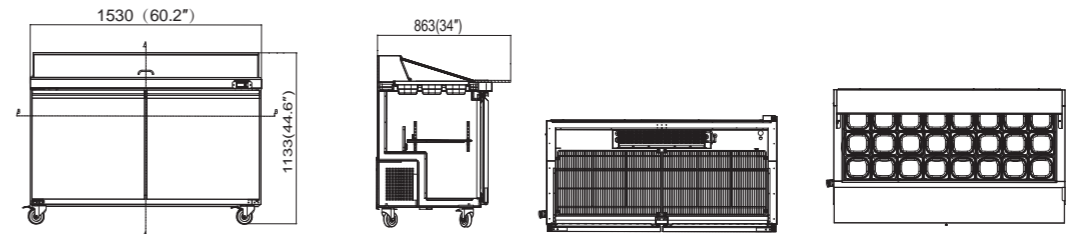

NSP-60(M)

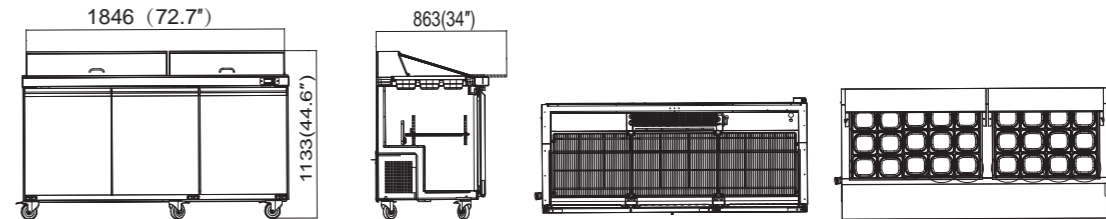

NSP-72(M)

Product Model	NSP-29(M)	NSP-48(M)	NSP-60(M)	NSP-72(M)
Unit dimensions (W / D/ H mm)	732*863*1133	1225*863*1133	1530*863*1133	1846*863*1133
Unit dimensions (W / D/ H inch)	29*34*44 5/8	48 1/4*34*44 5/8	60 1/4*34*44 5/8	72 11/16*34*44 5/8
Packing dimensions (W / D/ H mm)	782*829*1216	1275*829*1216	1580*829*1216	1899*829*1216
Packing dimensions (W / D/ H inch)	30 3/4*32 5/8*47 7/8	50 3/16*32 5/8*47 7/8	62 3/16*32 5/8*47 7/8	74 3/4*32 5/8*47 7/8
Net capacity (CUFT)	7.6	13.8	17.8	21.2
Net Capacity(L)	215L	390L	505L	601L
Cooling System	Ventilated	Ventilated	Ventilated	Ventilated
Temperature range(°F)	32~50	32~50	32~50	32~50
Kind Of Refrigerant	R290	R290	R290	R290
Number of Shelves	1	2	2	3
Number of Door	1	2	2	3
40 ' Container load	60	44	28	26

CHEF BASE



NCB-36TN

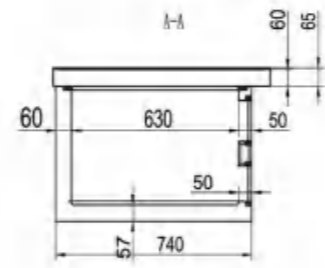
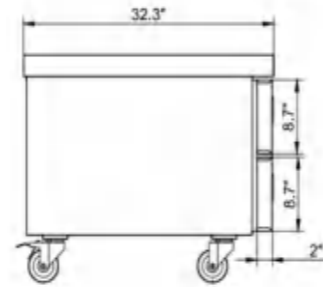
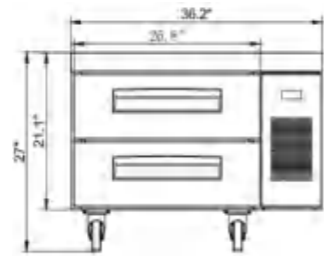

Standard Features

- Adjustable stainless steel feet or lockable castors
- Exterior material and interior material SS201
- Digital thermostat
- High quality compressor: Huayi
- With evaporator fan and condenser fan
- With drawers
- With strong castors

Options

- Exterior or interior material SS304



NCB-52TN

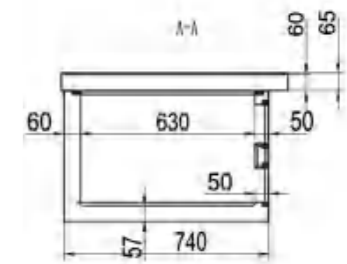
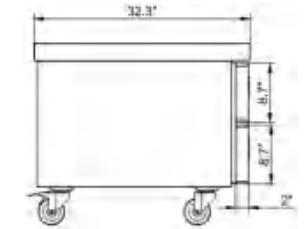
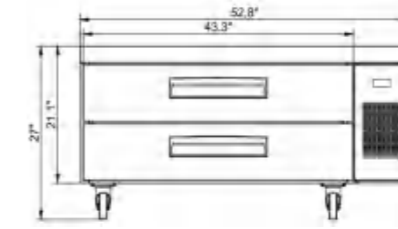

NCB-72TN

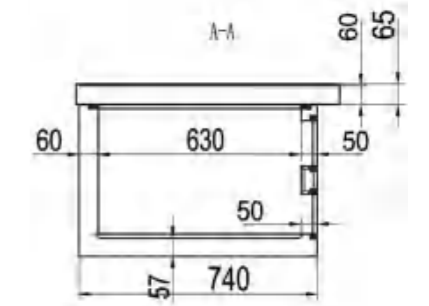
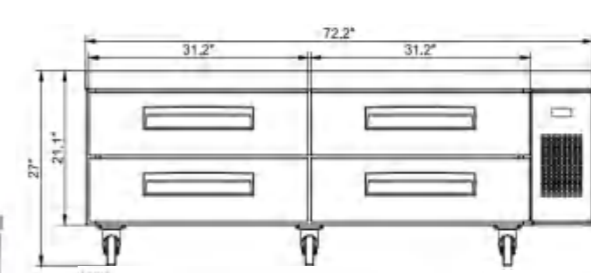

Product Model	NCB-36TN	NCB-52TN	NCB-72TN
Unit dimension (W/D/H mm)	920*820*685	1340*820*685	1835*820*685
Packing dimension (W/D/H mm)	980*880*730	1400*880*730	1895*880*730
Unit dimension (W/D/H inch)	36 1/4*32 15/16*26 15/16	52 3/4*32 15/16*26 15/16	72 1/4*32 15/16*26 15/16
Packing dimension (W/D/H inch)	38 9/16*34 5/8*28 3/4	55 1/8*34 5/8*28 3/4	74 5/8*34 5/8*28 3/4
Net capacity(CUFT)	4.66	7.94	11.79
Capacity(L)	132	225	334
Number of drawers	2	2	4
Cooling Type	Ventilated	Ventilated	Ventilated
Refrigerant	R290/60g	R290/75g	R290/100g
Temperature (F)	35~46	35~46	35~46
40 'HC Container loading	78	48	39

REFRIGERATED TOPPING UNIT

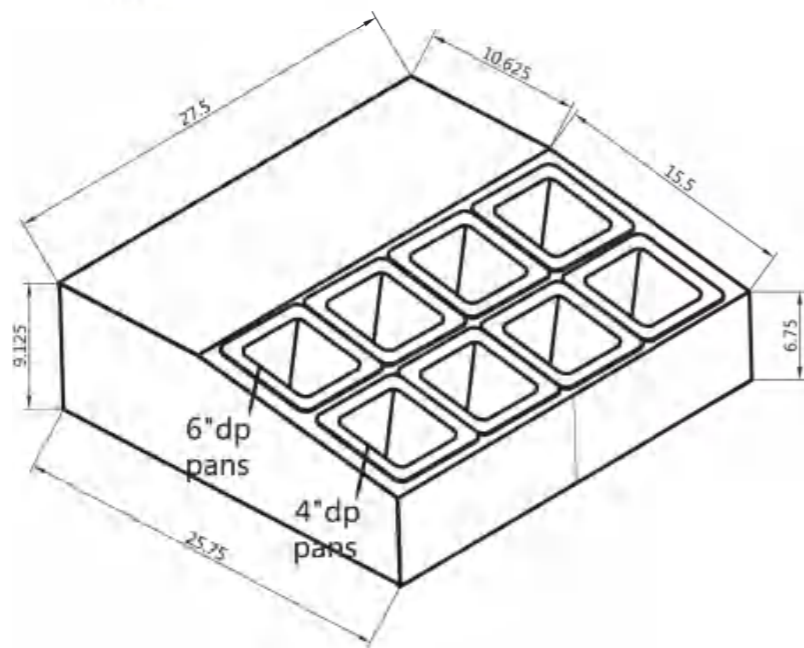

Standard Features

- Interior and exterior stainless steel material for high level product
- High quality famous compressor: Zanussi
- Accept GN1/6 pans range
- CFC free foaming
- R134a/R600a
- Adjustable feet

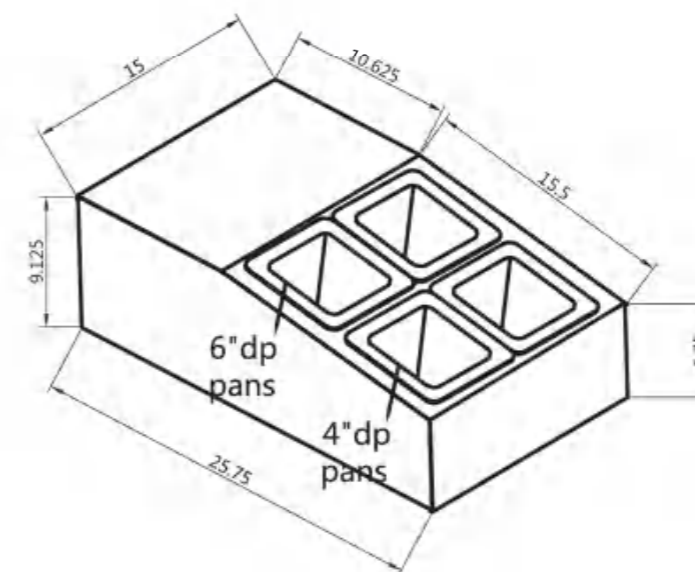

Product Model	RTR-4	RTR-8
Internal Dimension(W/D/H mm)	300*145*156 11 13/16*5 11/16*6 1/8	624*145*156 24 9/16*5 11/16*6 1/8
External Dimension WITH WEELS(W/D/H mm)	379*656*236 14 15/16*25 13/16*9 5/16	699*656*236 27 1/2*25 13/16*9 5/16
Packing Dimension(W/D/H mm)	450*715*380 17 11/16*28 1/8*14 15/16	770*715*380 30 5/16*28 1/8*14 15/16
Refrigerant	R600a	R600a
Net Volume	GN1/6*4	GN1/6*8
Cooling system	static	static
Temperature Control	Mechanical thermostat	Mechanical thermostat
Compressor standard	ZEL	ZEL
Temperature(°F)	32~50	32~50
40 ' Container loading	560	336

VRX



VRX-2000/330

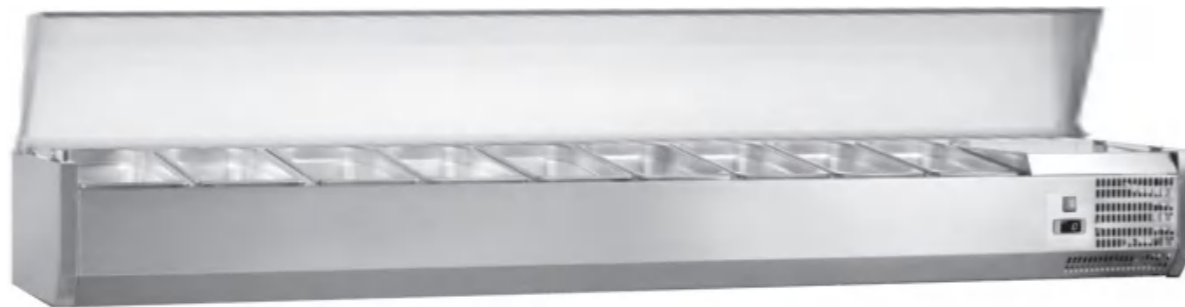

VRX-2000/380S/S LID/2 LIDS

Product Model	VRX-1000/330	VRX-1200/330	VRX-1400/330	VRX-1500/330	VRX-1600/330	VRX-1800/330	VRX-1800/330
Unit dimensions (W/D/H mm)	1000*335*435	1200*335*435	1400*335*435	1500*335*435	1600*335*435	1800*335*435	2000*335*435
Net capacity (L)	GN1/4*5	GN1/4*5	GN1/4*6	GN1/4*7	GN1/4*8	GN1/4*9	GN1/4*10
Cooling system	Static	Static	Static	Static	Static	Static	Static
Temperature (°C)	0~+10	0~+10	0~+10	0~+10	0~+10	0~+10	0~+10
Refrigerant	R290	R290	R290	R290	R290	R290	R290
40' Container loading	386	386	336	310	294	260	242

Standard Features

- European standard refrigerated topping unit
- Interior and exterior stainless steel material for high level product
- Adjustable feet

Options

- LED light

330 SERIES

380 SERIES

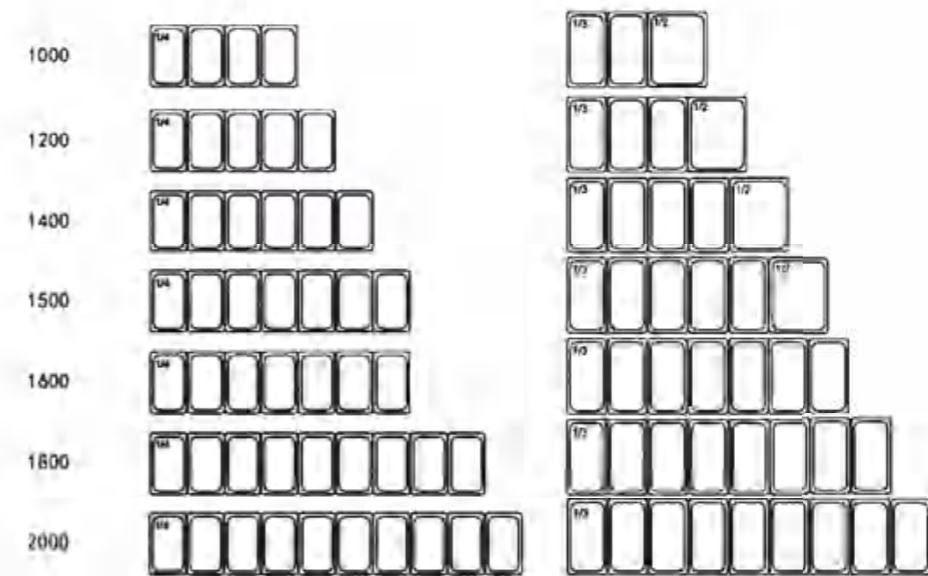

Product Model	VRX-1000/380	VRX-1200/380	VRX-1400/380	VRX-1500/380	VRX-1600/380	VRX-1800/380	VRX-2000/380
Unit dimensions (W/D/H mm)	1000*395*435	1200*395*435	1400*395*435	1500*395*435	1600*395*435	1800*395*435	2000*395*435
Net capacity (L)	GN1/3*2+ GN1/2*1	GN1/3*3+ GN1/2*1	GN1/3*4+ GN1/2*1	GN1/3*5+ GN1/2*1	GN1/3*7	GN1/3*8	GN1/3*9
Cooling system	Static	Static	Static	Static	Static	Static	Static
Temperature (°C)	0~+10	0~+10	0~+10	0~+10	0~+10	0~+10	0~+10
Refrigerant	R290	R290	R290	R290	R290	R290	R290
40' Container loading	385	323	280	261	247	218	196

Upright Chiller & Freezer

Ventilated
Adsorption liner



Standard Features

- HIPS liner, more sanitary and environmentally friendly
- New cooling air system (Ventilated + Wind deflector)
More beautiful and Energy saving
- Hot gas pipe assisted evaporating drain water
- Lock & key
- Electric thermostat
- BR/BF600 can put GN2/1 pan directly
- Reversible door (left or right)
- BR/BF200: 2+1/Others: 4+1 shelves

Options

- Top LED light
- Exterior and Interior color: Black or White
- Stainless steel external material
- More shelves



Model	External Dimension (mm)	Temperature Range (°C)	Effective Volume(L)	Input power (w)	Refrigerant	40'Container load(pcs)
BR200V	595x655x880	≤-18	115	63	R600a	108
BF200V	595x655x880	2~8	115	62	R600a	108
BR400V	595x662x1882	≤-18	293	66	R600a	54
BF400V	595x662x1882	2~8	293	135	R290	54
BR600V	775x762x1882	2~8	510	133	R290	42
BF600V	775x762x 1882	2~8	510	168	R290	42

Upright Chiller & Freezer

-with glass door
Ventilated
Adsorption liner



Standard Features

- HIPS liner, more sanitary and environmentally friendly
- New cooling air system (Ventilated + Wind deflector),
More beautiful and Energy saving
- Hot gas pipe assisted evaporating drain water
- Electric thermostat
- Lock & key
- BR/BF600 can put GN2/1 pan directly
- LED light
- BR/BF200: 2+1/Others: 4+1 shelves

Options

- Black & White stainless steel exterior and interior color
- Glass with electric heater
- More shelves



Model	External Dimension (mm)	Temperature Range (°C)	Effective Volume(L)	Display Area(M ²)	Input power (w)	Refrigerant	40'container load(pcs)
BR200VG	595x655x880	2~8	115	0.293	66	R600a	108
BF200VG	595x655x880	≤-18	115	0.293	175	R290	108
BR400VG	595x662x1882	2~8	306	0.689	135	R290	54
BF400VG	595x662x1882	≤-18	306	0.689	343	R290	54
BR600VG	775x762x1882	2~8	527	0.912	168	R290	42
BF600VG	775x762x1882	≤-18	527	0.912	445	R290	42

Back Bar with Hinged Door

Ventilated
Adsorption liner



Standard Features

- HIPS liner, more sanitary and environmentally friendly
- Ventilated(Finned evaporator+ Wind deflector)
- LED light
- 2 layers shelves
- Hot gas pipe assisted evaporating drain water

Options

- Stainless steel external material
- More shelves

Model	External Dimension (mm)	Temperature Range (°C)	Effective Volume(L)	Display Area(M ²)	Input power (w)	Refrigerant	40'Container load(pcs)
BBS-138H	600×520×900	2-8	134	0.379	81	R600a	144
BBD-238H	900×520×900	2-8	212	0.527	133	R290	96
BBT-338H	1350×520×900	2-8	328	0.791	135	R290	66

Back Bar with Sliding Door

Ventilated
Adsorption liner



Standard Features

- HIPS liner, more sanitary and environmentally friendly
- Ventilated(Finned evaporator) + Wind deflector
- Lock & key
- LED light
- 2 layers shelves
- Hot gas pipe assisted evaporating drain water

Options

- More shelves

Model	External Dimension (mm)	Temperature Range(°C)	Effective Volume(L)	Display Area(M ²)	Input power (w)	Refrigerant	40'Container load(pcs)
BBD-238S	900×520×900	2-8	212	0.472	133	R290	96
BBT-338S	1350x520x900	2-8	328	0.707	135	R290	66

Beverage Cooler

Ventilated
Adsorption liner



Standard Features

- HIPS liner, more sanitary and environmentally friendly
- Ventilated
- Hot gas pipe assisted evaporating drain water
- New inset LED light to improve products visibility
- Double tempered glass, Better insulation
- Lock & key
- C: with canopy
T: without canopy

Options

- Black & White exterior and interior color
- Glass with Electric heater
- More shelves

Model	External Dimension (mm)	Temperature Range(°C)	Effective Volume(L)	Display Area(M ²)	Input power (w)	Refrigerant	40'Container load (pcs)
SC-188VC	500×596×1531	2-8	181	0.34	81	R600a	75/103
SC-198VT	500×596×1531	2-8	188	0.376	81	R600a	75/103
SC-288VC	550×596×1801	2-8	249	0.503	133	R290	57/75
SC-298VT	550×596×1801	2-8	258	0.544	133	R290	57/75
SC-388VC	595×626×1946	2-8	348	0.624	168	R290	54/71
SC-398VT	595×626×1946	2-8	356	0.67	168	R290	54/71
SC-488VC	700×676×1946	2-8	468	0.759	168	R290	48
SC-498VT	700×676×1946	2-8	478	0.814	168	R290	48

Beverage Cooler

Ventilated
Adsorption liner

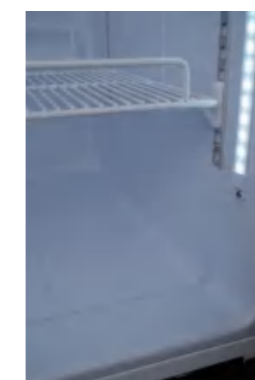

Standard Features

- HIPS liner, more sanitary and environmentally friendly
- Ventilated
- Hot gas pipe assisted evaporating drain water
- New inset LED light to improve products visibility
- Double tempered glass ,Better insulation
- Lock & key
- C: with canopy
T: without canopy

Options

- lack & White exterior and interior color
- Glass with Electric heater
- More shelves

Model	External Dimension W/D/H(mm)	Temperature Range(°C)	Effective Volume(L)	Display Area (M ²)	Input power (w)	Refrigerant	40'Container load(pcs)
SC-788VC	1000×745×1973	2-8	736	0.994	258	R290	33
SC-798VT	1000×745×1973	2-8	751	1.06	258	R290	33
SC-1088VC	1300×745×1973	2-8	1001	1.373	258	R290	25
SC-1098VT	1300×745×1973	2-8	1020	1.463	258	R290	25



QINGDAO NEWSTAR COMMERCIAL EQUIPMENT CO.,LTD

ADD: No.6, Ying Shang road, Bei an industrial park , Jimo District, Qingdao City, China

Email: info@nsrcc.com

www.nsrcc.com